

SBCCI®

PST & ESI®

SBCCI PUBLIC SAFETY TESTING AND EVALUATION SERVICES INC.

900 Montclair Road, Suite A; Birmingham, Alabama 35213-1206

www.sbccies.org

a Participating Member of the NES, Inc.

Evaluation Reports are the opinion of the Committee on Evaluation, based on the findings, and do not constitute or imply an approval or acceptance by any local community. The Committee, in review of the data submitted, finds that in their opinion the product, material, system, or method of construction specifically identified in this report conforms with or is a suitable alternate to that specified in the Standard and International Codes,

SUBJECT TO THE LIMITATIONS IN THIS REPORT

The Committee on Evaluation has reviewed the data submitted for compliance with the *Standard Building Code*®, the *SBCCI Standard for Hurricane Resistant Residential Construction*® *SSTD 10-99*, and the International One and Two Family Dwelling Code and submits to the Building Official or other authority having jurisdiction the following report. The Committee on Evaluation, SBCCI PST & ESI and its staff are not responsible for any errors or omissions to any documents, calculations, drawings, specifications, tests or summaries prepared and submitted by the design professional or preparer of record that are listed in the Substantiating Data Section of this report. Portions of this report were previously included in Evaluation Reports #9910. Copyrighted © 2001 SBCCI PST & ESI

REPORT NO.: 9910A

EXPIRES: See current SBCCI PST & ESI EVALUATION REPORT LISTING

CATEGORY: HANGERS AND SUPPORTS

SUBMITTED BY:

HURRI-BOLT, INC.
2716 N. 46TH STREET
TAMPA, FLORIDA 33605 1-
800-226-6888
www.hurribolt.com

1. PRODUCT TRADE NAME

Hurri-Bolt™ Anchors:

- 1.1 Hurri-Bolt™ Top Plate Tie Down
- 1.2 Hurri-Bolt™ Truss Tie Down (Patent #6,161,339)

2. SCOPE OF EVALUATION

Structural:

- 2.1 Wind Load Uplift
- 2.2 Wind Load Lateral

3. USES

Hurri-Bolt™ Anchors are used to anchor wood stud walls and roof framing members to the foundation.

4. DESCRIPTION

4.1 General

Hurri-Bolt™ Anchors are fabricated roof and wall anchoring systems consisting of steel tie rods, eye bolts, Skip Bolts, turnbuckles, coupling nuts, steel aircraft cable, and anchor bolts which are combined to anchor roof trusses and rafters to walls and the walls to the foundation. An anchor bolt is embedded in the concrete foundation or a threaded rod is installed in hardened concrete with adhesive. Using a coupler, the rod assembly is attached to the anchor bolt. The eye bolt and Skip Bolt project above the top plate of the wall and a steel aircraft cable is threaded through the eye bolts and anchored to the Skip Bolts to anchor the trusses or rafters. A rod assembly using a washer and nut instead of eye bolts and Skip Bolts is used to provide a top plate anchor. The two tie down systems are described below. See Figures 1 and 2.

4.1.1 Hurri-Bolt Top Plate Tie Down: A Hurri-Bolt Anchor Bolt is installed in the concrete foundation. The anchor is threaded to receive a washer and hex nut to hold down the sill plate and receive a coupling nut. An ASTM A 563 Grade A hex coupling nut is threaded onto the anchor bolt. After the walls are framed, a Hurri-Bolt rod is threaded into the coupling nut. If the building is more than one story, the lower rod is attached to the upper rod with an additional coupling nut. The highest rod extends through the top plates and is secured by a washer and hex nut. The rods vary from 3/8 inch to 3/4 inch diameter depending on the wind uplift load. The roof trusses must be anchored to the top plate to resist their design loads. See Figure 2.

4.1.2 Hurri-Bolt Truss Tie Down: A Hurri-Bolt Anchor bolt is installed in the concrete foundation. The anchor is threaded to receive a washer and hex nut to hold down the sill plate and receive a coupling nut. An ASTM A 563 Grade A hex coupling

nut is threaded onto the anchor bolt. The Hurri-Bolt rod of the proper length is threaded onto the coupling nut. The rod is threaded to a turnbuckle. A welded eye bolt is inserted through a hole drilled in the top plate and threaded into the turn-buckle body. A length of 5/16 inch, 7x19, aircraft cable is laid across the tops of the trusses that have been notched to receive the cable and the cable is threaded through the eye bolts. A Truss Bearing Enhancer 4 inch x 2 inch x 1/8 inch steel is placed within the truss notch, between the truss top chord and the aircraft cable.

A Skip Bolt is installed in lieu of the eye bolt at each end of the cable run and is threaded into the turnbuckle body. See Figure 1.

4.2 Materials

4.2.1 Hurri-Bolt Cast in Place Anchor Bolt - HBA: 1/2, 5/8, and 3/4 inch diameter threaded steel rods, ASTM A 193 B7, minimum yield strength of 123 ksi. The bolts are 12 inches long with 3 inch thread at top and 2-1/2 inches of thread at the bottom. The rods are supplied with either a 2 inch square x 1/8 inch steel washer ASTM F 844 or 1-3/8 inch diameter x 9/16 inch steel washer at the bottom with std. hex nut above and below the washer. The top of the bolt has a washer and hex nut (HBSS and HBN). Nuts conform to ASTM A 563 Grade A/ANSI B18.2.2. An alternate anchor bolt is a 1/2 inch diameter bent anchor bolt 12 inches long x 3 inches with 3 inch threaded nut and washer per ASTM A 193 B7 steel.

4.2.2 Hurri-Bolt Epoxy Studs - HBE: 1/2, 5/8, and 3/4 inch diameter threaded steel rods, ASTM A 193 B7, minimum yield strength of 123 ksi. Installed using Hurri-Bolt Epoxy HB2, HB10 see section 4.2.12 below. The Hurri-Bolt Epoxy Studs are installed with a 12 diameter embedment – 1/2 inch diameter is 6 inch embedment, 5/8 inch diameter is 7-1/2 inch embedment and 3/4 inch diameter is 9 inch embedment. The top of the bolt has a washer and hex nut (HBSS and HBN). Nuts conform to ASTM A 563 Grade A/ANSI B18.2.2. Special Inspection is required for installing Hurri-Bolt Epoxy Studs HBE, see section 5.4 of this report.

4.2.3 Hurri-Wedge Anchors - HW: 1/2. inch diameter anchors, C 1038/1040 steel with Epoxy Electrocoat coating. Length 9 inches with a 6-5/8 inch embedment. A pilot hole is pre-drilled using a carbide-tipped Hurri-Wedge Bit - HWB dyed blue, supplied by Hurri-Bolt, Inc., with bit diameter matched to the anchor size. The drill bit size range is 0.490 to 0.495 inch in diameter for 1/2 inch Hurri-Wedges. The hole must be drilled to a minimum depth of 1/2 inch deeper than the required embedment. After the dust is removed from the drilled hole, the Hurri-Wedge is driven using an impact wrench and Hurri-Bolt coupling Nuts with stops in the center. Special Inspection is required for installing Hurri-Wedge Anchors, see section 5.4 of this report.

Anchors shall not be installed before the concrete has developed its design strength.

The hole depth must be sufficient to provide the minimum embedment depth for the anchor as specified in the tables in this report. The hole must be clean, free of dust, debris and standing water. The anchors are permitted to be installed in holes that are wet, but standing water must be removed. A nylon brush and compressed air are used to clean the hole.

4.2.4 Hurri-Bolt Framing Rod - HBR: 3/8, 1/2, 5/8, and 3/4 inch diameter rods threaded at each end 6 feet long, SAE C 1008 or ASTM A 36.

4.2.5 Hurri-Bolt Top Plate Rod - HBT: 3/8, 1/2, 5/8, and 3/4 inch diameter rods fully threaded 6 feet long, SAE C 1008 or ASTM A 36. Rods can fabricated to specific lengths per job.

Diameter (in) HBR or HBT	Material	Yield Strength (ksi)
3/8	C 1008	55.9
1/2	C 1008	55.9
5/8	A 36(Mod)	64.1
3/4	A 36(Mod)	64.1

4.2.6 Hurri-Bolt Coupling Nut - HBC: sizes 3/8, 1/2, 5/8, 3/4 inch, ASTM A 563 Grade A.

4.2.7 Turnbuckle Bodies: 1/2 inch x 6 inch Forged, carbon steel, 2,300 pound rated capacity (FS =5:1).

4.2.8 Eye Bolt: SAE C 1006 steel, fabricated 1 inch I.D. eye bolt welded at point of closure, thread length 6-1/2 inches with 1/2-13 LHT threads, diameter 0.440 inches. Minimum yield strength 55.9 ksi.

4.2.9 Skip Bolt: SAE C 1006 fabricated steel U shaped, rod 0.440 inches in diameter, one leg 10-3/4 inches long with 5-1/2 inches 1/2-13 LHT threads and other leg 8-1/2 inches with 6-1/2 RHT threads, bend radius 3/4 inch. Minimum yield strength 55.9 ksi.

4.2.10 Aircraft Cable: 0.313 (5/16") inch, 7x19 Type IA aircraft cable with a breaking strength of 9,800 pounds. MIL-DTL-83420F. Forged Wire Rope Clips are supplied for the connecting cables.

4.2.11 Top Plate Washers HBST: punched washers complying with ASTM A 568. Sizes see Design Tables for sizes.

4.2.12 Truss Top Chord Bearing Enhancer: 4 inch x 2 inch x 1/8 inch thick ASTM A 36 steel plate stamped to receive the aircraft cable.

4.2.13 Hurri-Bolt Sill Plate Washers - HBSS: 2 inch square punched washer x 1/8 inch thick, complying with ASTM A 568.

4.2.14 Hurri-Bolt Nuts - HBN: conforming to ASTM A563 Grade A/ANSI B 18.2.2.

4.2.15 Hurri-Bolt Epoxy- HB22, HB10 (Ultrabond 1 by U. S. Anchor Corporation) injection Epoxy Adhesive: The adhesives consist of a two component epoxy system, contained in two cartridges that separate the resin from the hardener. The two components are combined when dispensed through a static mixing nozzle supplied by U.S. Anchor. Each component has a two-year shelf life when stored in the manufacturer's unopened containers at temperatures above 40° F (4.4° C).

Ultrabond 1 is a concrete adhesive anchorage system used for bonding threaded rods in minimum 2,000 psi (13.7 Mpa) normal weight concrete. When threaded rods are installed in concrete, Ultrabond 1 adhesive is permitted to resist dead, live, seismic and wind loads. Special Inspection is required for installing Ultrabond 1, see section 5.4 of this report.

Anchors shall be installed in holes predrilled with a carbide-tipped masonry drill manufactured within the range of the maximum and minimum drill tip dimensions of ANSI Standard B 212.15 for the allowable values set forth in this report.

Anchors shall not be installed before the concrete has developed its design strength.

The hole depth must be sufficient to provide the minimum embedment depth for the anchor as specified in the tables in this report. The hole must be clean, free of dust, debris and

standing water. The anchors are permitted to be installed in holes that are wet, but standing water must be removed. A nylon brush and compressed air are used to clean the hole. The holes are filled to 3/4 of their capacity with the epoxy adhesive and the threaded steel anchor or reinforcing bar is installed in the hole with a rotating motion until the bottom of the hole is reached. After anchor installation the anchors must be allowed to cure before application of design loads for a period of time prescribed by the manufacturer.

4.3 Design Loads

Maximum allowable design loads for the anchors are given in Tables 1 through 7. Design loads on the buildings shall be determined in accordance with Chapter 16 of the *Standard Building Code* and shall not exceed the loads shown in the Tables.

**TABLE 1 - ALLOWABLE UPLIFT LOAD (LBS)
3/8 INCH HURRI-BOLT TOP PLATE TIE DOWN**

Anchor Type (Note 3)	Washer Size (Note 4)	Concrete Strength (psi)							
		2500		3000		3500		4000	
		SPF(5)	SYP(5)	SPF(5)	SYP(5)	SPF(5)	SYP(5)	SPF(5)	SYP(5)
HBA	A	1950	2405	1950	2405	1950	2405	1950	2405
	B	2405	2405	2405	2405	2405	2405	2405	2405
HBE	A	1950	2405	1950	2405	1950	2405	1950	2405
	B	2405	2405	2405	2405	2405	2405	2405	2405
HW	A	1950	2405	1950	2405	1950	2405	1950	2405
	B	2405	2405	2405	2405	2405	2405	2405	2405

Table 1 Notes:

- SI Units conversion: 1 in. = 25.4 mm, 1 lbf = 4.5 N., 1 psi = 6.9 kPa.
- The allowable design loads are in pounds and shall not be increased for duration of load.
- Each Assembly uses a 1/2 inch anchor and a 1/2 inch to 3/8 inch reducer coupler and 3/8 inch rod.
HBA is Cast in place anchor, minimum 9 inch embedment and 1-3/4 inch edge distance.
HBE is Epoxy Stud anchor, minimum 6 inch embedment and 1-3/4 inch edge distance.
HW is Hurri-Wedge anchor, minimum 6-5/8 inch embedment and 1-3/4 inch edge distance.
HBE Epoxy is Hurri-Bolt Epoxy HB22, HB10 (Ultrabond 1 by U. S. Anchor Corporation) see section 4.2.15 above. Special Inspection is required for installation of Hurri-Bolt Epoxy, see section 5.4 below.
Special Inspection is required for installation of Hurri-Wedge Anchors, see section 5.4 below
- Washer sizes:
A: 2 inch x 2 inch x 1/8 inch with 7/16 inch hole.
B: 2-1/2 inch x 2-1/2 inch x 3/16 inch with 7/16 inch hole.
- Double top plates are required, either **SYP** Southern Pine No. 2 Grade with a F'c = 565 psi or **SPF** Spruce Pine Fir No. 2 Grade with an F'c = 425 psi, perpendicular to grain.

**TABLE 2 - ALLOWABLE UPLIFT LOAD (LBS)
1/2 INCH HURRI-BOLT TOP PLATE TIE DOWN**

Anchor Type (Note 3)	Washer Size (Note 4)	Concrete Strength (psi)							
		2500		3000		3500		4000	
		SPF(5)	SYP(5)	SPF(5)	SYP(5)	SPF(5)	SYP(5)	SPF(5)	SYP(5)
HBA	B	2930	3900	2930	3900	2930	3900	2930	3900
	B-Slot	2810	3740	2810	3740	2810	3740	2810	3740
	C	4010	4010	4010	4010	4010	4010	4010	4010
	C-Slot	4010	4010	4010	4010	4010	4010	4010	4010
HBE	B	2930	3804	2930	3804	2930	3804	2930	3804
	B-Slot	2810	3804	2810	3740	2810	3740	2810	3740
	C	3804	3804	3804	3804	3804	3804	3804	3804
	C-Slot	3804	3804	3804	3804	3804	3804	3804	3804
HW	B	2930	3436	2930	3900	2930	3900	2930	3900
	B-Slot	2810	3436	2810	3740	2810	3740	2810	3740
	C	3436	3436	3905	3905	4010	4010	4010	4010
	C-Slot	3436	3436	3905	3905	4010	4010	4010	4010

Table 2 Notes:

- SI Units conversion: 1 in. = **25.4** mm, 1 lbf = 4.5 N., 1 psi = 6.9 kPa.
- The allowable design loads are in pounds and shall not be increased for duration of load.
- Each Assembly uses a 1/2 inch anchor and a 1/2 inch coupler with 1/2 inch rod.
HBA is Cast in place anchor, minimum 9 inch embedment and 1-3/4 inch edge distance.
HBE is Epoxy Stud anchor, minimum 6 inch embedment and 1-3/4 inch edge distance.
HW is Hurri-Wedge anchor, minimum 6-5/8 inch embedment and 1-3/4 inch edge distance.
 HBE Epoxy is Hurri-Bolt Epoxy HB22, HB10 (Ultradond 1 by U. S. Anchor Corporation) see section 4.2.15 above. Special Inspection is required for installation of Hurri-Bolt Epoxy, see section 5.4 below.
 Special Inspection is required for installation of Hurri-Wedge Anchors, see section 5.4 below.
- Washer sizes:
B: 2-1/2 inch x 2-1/2 inch x 3/16 inch with 9/16 inch holes.
B-Slot: 2-1/2 inch x 2-1/2 inch x 3/16 inch with 9/16 inch x 1 inch slotted hole.
C: 3 inch x 3 inch x 1/4 inch with 9/16 inch hole.
C-Slot: 3 inch x 3 inch x 1/4 inch with 9/16 inch x 1 inch slotted hole.
- Double top plates are required, either **SYP** Southern Pine No. 2 Grade with a F'c = 565 psi or **SPF** Spruce Pine Fir No. 2 Grade with an F'c = 425 psi, perpendicular to grain.

**TABLE 3 - ALLOWABLE UPLIFT LOAD (LBS)
5/8 INCH HURRI-BOLT TOP PLATE TIE DOWN**

Anchor Type (Note 3)	Washer Size (Note 4)	Concrete Strength (psi)							
		2500		3000		3500		4000	
		SPF(5)	SYP(5)	SPF(5)	SYP(5)	SPF(5)	SYP(5)	SPF(5)	SYP(5)
HBA	C	4140	5485	4140	5485	4140	5485	4140	5485
	D	5600	7050	5600	7050	5600	7050	5600	7050
HBE	C	4140	5372	4140	5372	4140	5372	4140	5372
	D	5372	5372	5372	5372	5372	5372	5372	5372

Table 3 Notes:

- SI Units conversion: 1 in. =25.4 mm, 1 lbf=4.5 N., 1 psi =6.9 kPa.
- The allowable design loads are in pounds and shall not be increased for duration of load.
- Each Assembly uses a 5/8 inch anchor and a 5/8 inch coupler and 5/8 inch rod.
HBA is Cast in place anchor, minimum 9 inch embedment and 1-3/4 inch edge distance.
HBE is Epoxy Stud anchor, minimum 7-1/2 inch embedment and 1-3/4 inch edge distance..
HBE Epoxy is Hurri-Bolt Epoxy HB22, HB10 (Ultrabond 1 by U. S. Anchor Corporation) see section 4.2.15 above. Special Inspection is required for installation of Hurri-Bolt Epoxy, see section 5.4 below.
- Washer sizes:
C: 3 inch x 3 inch x 1/4 inch with 11/16 inch hole.
D: 3-1/2 inch x 3-1/2 inch x 1/4 inch with 11/16 inch hole.
- Double top plates are required, either **SYP** Southern Pine No. 2 Grade with a F'c = 565 psi or **SPF** Spruce Pine Fir No. 2 Grade with an F'c = 425 psi, perpendicular to grain.

**TABLE 4 - ALLOWABLE UPLIFT LOAD (LBS)
3/4 INCH HURRI-BOLT TOP PLATE TIE DOWN**

Anchor Type (Note 3)	Washer Size (Note 4)	Concrete Strength (psi)							
		2500		3000		3500		4000	
		SPF(5)	SYP(5)	SPF(5)	SYP(5)	SPF(5)	SYP(5)	SPF(5)	SYP(5)
HBA	C	4070	5420	4070	5420	4070	5420	4070	5420
	D	5530	7360	5530	7360	5530	7360	5530	7360
HBE	C	4070	5420	4070	5420	4070	5420	4070	5420
	D	5372	7360	5372	7360	5372	7360	5372	7360

Table 4 Notes:

- SI Units conversion: 1 in. = 25.4 mm, 1 lbf = 4.5 N., 1 psi = 6.9 kPa.
- The allowable design loads are in pounds and shall not be increased for duration of load.
- Each Assembly uses a 3/4 inch anchor and a 3/4 inch coupler and 3/4 inch rod.
HBA is Cast in place anchor, minimum 9 inch embedment and 1-3/4 inch edge distance.
HBE is Epoxy Stud anchor, minimum 9 inch embedment and 1-3/4 inch edge distance..
HBE Epoxy is Hurri-Bolt Epoxy HB22, HB10 (Ultrabond 1 by U. S. Anchor Corporation) see section 4.2.15 above. Special Inspection is required for installation of Hurri-Bolt Epoxy, see section 5.4 below.
- Washer sizes:
C: 3 inch x 3 inch x 1/4 inch with 13/16 inch hole.
D: 3-1/2 inch x 3-1/2 inch x 1/4 inch with 13/16 inch hole.
- Double top plates are required, either **SYP** Southern Pine No. 2 Grade with a F'c = 565 psi or **SPF** Spruce Pine Fir No. 2 Grade with an F'c = 425 psi, perpendicular to grain.

**TABLE 5 - ALLOWABLE UPLIFT LOAD
HURRI-BOLT TRUSS TIE DOWN**

Spacing/ No. Trusses	Uplift Load (lbs per truss)
72 inches/ 3 trusses	945
48 inches / 2 trusses	1500

Table 5 Notes:

1. SI Units conversion: 1 in. = 25.4 mm, 1 lbf = 4.5 N., 1 psi = 6.9 kPa.
2. The uplift loads listed in the table shall not be increased for duration of load.
3. The rod assembly is installed in concrete foundations as described in Section 5.2 and is continuous to roof trusses. Allowable design loads are shown in the Table.

**TABLE 6 - ALLOWABLE TRANSVERSE AND LONGITUDINAL LOADS
HURRI-BOLT TRUSS TIE DOWN**

Load Direction	lbs per truss
Transverse	360
Longitudinal	640

Table 6 Notes:

1. SI Units conversion: 1 in.=25.4mm,1lbf=4.5N.,1psi=6.9kPa.
2. The uplift loads listed in the table shall not be increased for duration of load.
3. The rod assembly is installed in concrete foundations as described in Section 5.2 and is continuous to roof trusses. Allowable design loads are shown in the Table.

5. INSTALLATION

5.1 General

Hurri-Bolt™ Anchors are installed in accordance with the manufacturer's published installation instructions and this report.

The manufacturer's published installation instructions and this report shall be strictly adhered to and a copy of these instructions shall be available at all times on the job site during installation.

The instructions within this report govern if there are any conflicts between the manufacturer's instructions and this report.

5.2 Foundations

Hurri-Bolt™ Anchor Bolts are embedded into concrete foundations that are minimum 12 inches thick with a minimum compressive strength as required in the design tables. The bolts shall have a minimum edge distance as noted in the design tables and shall be spaced as required to resist wind uplift load. The foundations shall be designed to resist the design loads determined in accordance with Chapter 16 of the Code.

5.3 Wall Construction

Wood framed walls shall be constructed of either Southern Pine, No 2 Grade, G = 0.55 or Spruce-Pine-Fir, No. 2 Grade,

G = 0.42, minimum **2 inch nominal thickness. All walls shall have double top plates.**

5.4 Special Inspection - Hurri-Bolt Epoxy Studs HBE with Hurri-Bolt Epoxy HB22, HB10 and Hurri-Wedge Anchors

Special Inspection is required for Ultrabond 1 adhesive anchoring systems. The owner or the registered design professional in responsible charge acting as the owner's agent shall employ one or more special inspectors to provide inspection of the construction involved. The special inspector shall be a registered design professional, an SBCCI certified building inspector, and employee of an SBCCI PST & ESI or NES listed quality assurance or inspection agency, or other third party qualified person who demonstrates competence to the satisfaction of the building official.

Such inspection shall be of a nature as to determine that the construction and quality of work are in accordance with the contract drawings and specifications and the manufacturer's installation instructions.

Items to be verified by the special inspector include hole diameter, cleanliness of hole and rod, adhesive type, adhesive application, rod diameter, rod embedment, grade of steel, and other requirements specified in this report and the manufacturer's instructions.

FIGURE 1
HURRI-BOLT TRUSS TIE DOWN SYSTEM

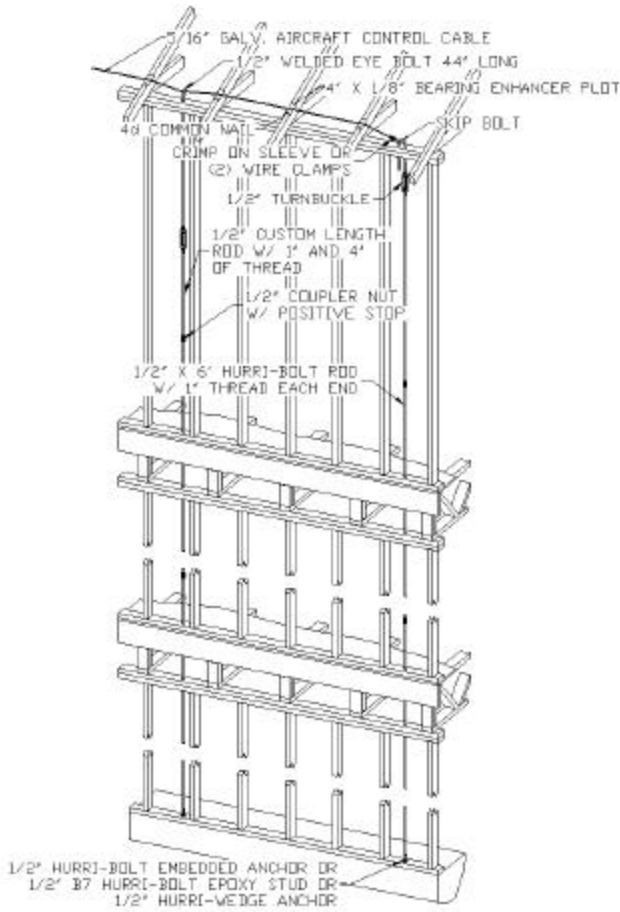

FIGURE 2
HURRI-BOLT TOP PLATE TIE DOWN SYSTEM
(1/2 inch Diameter Shown)

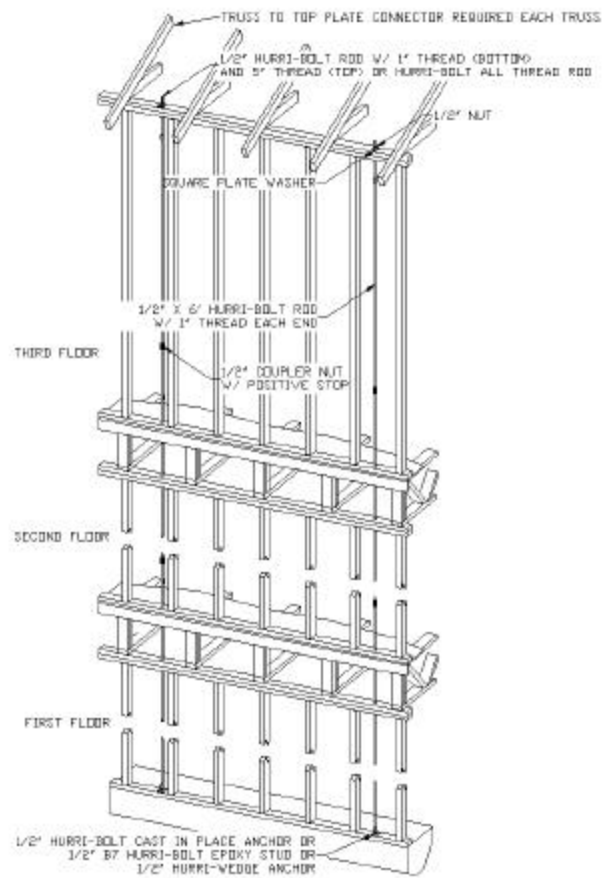

FIGURE 3
HURRI-BOLT CAST IN PLACE ANCHOR

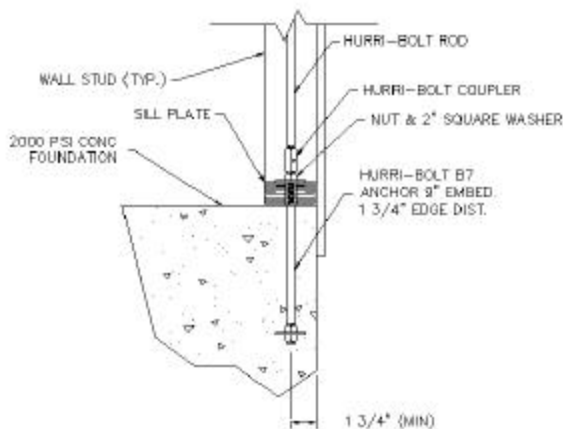
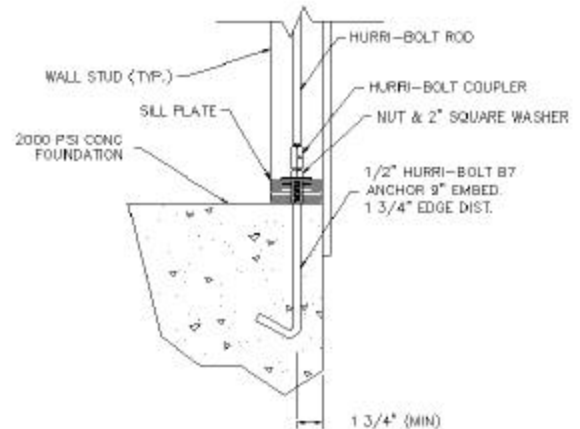
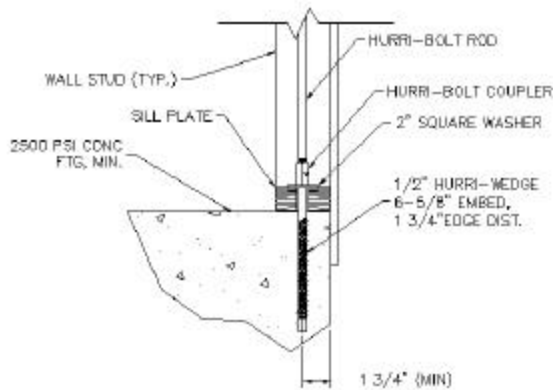

FIGURE 4
HURRI-BOLT ALTERNATE CAST IN PLACE ANCHOR -HBA
(1/2 inch Diameter Shown)



**FIGURE 5
HURRI-WEDGE ANCHOR – HW
(1/2 inch Diameter Shown)**



**FIGURE 6
HURRI-BOLT EPOXY ANCHOR – HBE
(1/2 inch Diameter Shown)**

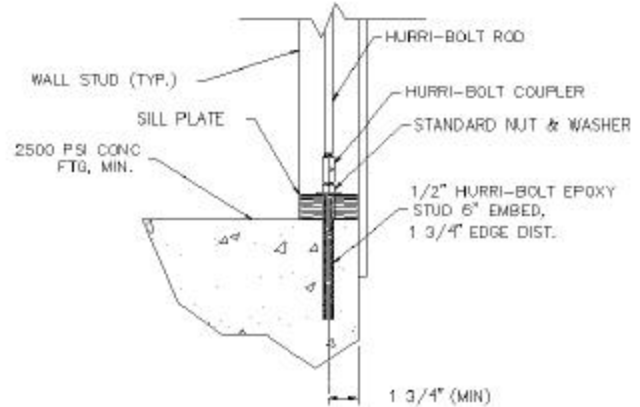

6. SUBSTANTIATING DATA

- 6.1 Manufacturer's descriptive literature, specifications and installation instructions.
- 6.2 Test report, structural uplift and lateral load testing, Celotex Corporation Testing Services, MTS Job No. 258600, September 3, 1998, signed by W. A. Jackson. Lateral Resistance Addendum, September, 1998. Letter report clarifying test procedure, October 28, 1998, signed by W.A. Jackson.
- 6.3 Concrete compressive strength, PSI, Report No. 779-80166-2, August 6, 1998.
- 6.4 Mill order certificates and specifications for materials:
 - 6.4.1 Specifications and composition of C 1006 Rolled steel rods by Vulcan Threaded Products, Inc., 10.22.98.
 - 6.4.2 Washer data sheet and ASTM F 844 Standard Specification for washers, steel, plain (flat), unhardened for general use.
 - 6.4.3 Specifications for Wire rope, Flexible, for aircraft Control (NIL-DTL-83420F).
 - 6.4.4 Specifications for lumber used in construction of test assemblies.
 - 6.4.5 Certified Mill Test Report by Birmingham S.E., LLC. 9/16" & 0.667" Rods.
 - 6.4.6 Test certification, Vulcan Threaded Products, 8/21/98, Eye-Bolts & Skip Bolts™.
 - 6.4.7 Quality certification, ASTM A 193 B7, Anchor Bolts Studs, 8/3/98.
 - 6.4.8 ASTM A 563 Carbon and Alloy Steel Nuts, Grade A coupler.
 - 6.4.9 Edward Daniel Co., Catalogue, Page 8, 1/2" x 6 inch Turnbuckles. 6.4.10 Industrial Galvanizers Southeast, Inc. conformance standards.
- 6.5 Engineering calculations, Catalano Engineering, Inc., 10/27/98, signed and sealed by James Catalano, P.E., 10/27/98. Revised Engineering Analysis, 12/31/98, signed and sealed by James Catalano, P.E.

- 6.6 Test report on anchor bolts in concrete tension testing, Celotex Corporation Testing Services, MTS Job NO. 520069, October 16, 1998, signed by W. A. Jackson.
- 6.7 Test reports on shear and tension testing under ASTM E 488 for Ultrabond 1 by U. S. Anchor Corporation, testing by Applied Research Laboratories, signed by Ovide N. Mercure III, Alan B. Sukert and signed and sealed by Christopher A. Hamon, P.E.:
 - 6.7.1 Shear tests, 12D embedment, shear perpendicular to edge distance of 1.75 inches L/N 29969, 06/29/99.
 - 6.7.2 Tension tests, 12D embedment, L/N 29970, 06/28/99.
 - 6.7.3 Shear tests, 12D embedment, shear parallel to edge distance of 1.75 inches, L/N 30011, 09/28/99.
- 6.8 Test reports on tension testing under ASTM E 488 for Hurri-Wedge 1/2 inch, Applied Research laboratories, signed by T. J. Bland and Alan B. Sukert, and signed and sealed by Christopher A. Hammon, P.E.:
 - 6.8.1 2000 psi concrete, L/N 30181, 01/03/01.
 - 6.8.2 4000 psi concrete, L/N 30187, 01/03/01.
- 6.9 Engineering calculations, signed and sealed by R.D. Hall, P.E.;
 - 6.9.1 Wood bearing, epoxy pullout test values, 11/5/00.
 - 6.9.2 Hurri-Wedge pullout capacities testing and interpolation, 1/10/01.
 - 6.9.3 Washer bearing calculations, 4/20/01.
 - 6.9.4 Design Load tables. 4/20/01.

7. CODE REFERENCES

Standard Building Code©-1999 Edition

Section 103.7	Alternate Materials and Methods
Section 1606	Wind Loads
Section 1609	Load Combinations
Chapter 17	Structural Tests and Inspections
Chapter 18	Foundations and Retaining Walls
Chapter 19	Concrete
Section 1914	Headed Bolts and Headed Stud Anchors in Concrete

Chapter 22	Steel
Section 2301.2	Wood Construction – Design
Section 2306.2	Other Fastenings
Section 2307	Floor Framing
Section 2308	Vertical Framing
Section 2309	Roof and Ceiling Framing

SBCCI Standard for Hurricane Resistant Residential Construction© SSTD 10-99

Section 101.4	Alternate Materials and Methods
Section 101.6.2	Design Concepts - Exterior Walls
Section 104	Design Criteria
Chapter 3	Buildings With Wood-Framed Exterior Walls
Section 302.1	Fasteners and Connectors
Section 303.2.3	Sill Plate to Foundation Anchorage
Section 303.3.2	Wall to Foundation Anchorage - Monolithic Slab-On-Grade Foundations
Section 305.3	Connections for Exterior Wall Framing
Section 305.7	Holddown Connectors
Section 307	Roof Systems
Section 307.1.5	Connections - Rafter-Joist Systems
Section 307.2.6	Connections - Truss Framing Systems
Chapter 4	Combined Concrete or Masonry And Wood Exterior Wall Construction

International One and Two Family Dwelling Code – 1998 Edition

Section 108	Alternate Materials and Systems
Section 301	Design Criteria
Section 403	Footings
Chapter 5	Floors
Chapter 6	Wall Construction
Table 602.3a	Fastener Schedule for Structural Members
Chapter 8	Roof-Ceiling Construction

8. COMMITTEE FINDINGS

The Committee on Evaluation in review of the data submitted finds that, in their opinion, the Hurri-Bolt™ Anchors as described in this report conform with or are suitable alternates to that specified in the *Standard Building Code©*, the *SBCCI Standard for Hurricane Resistant Residential Construction© SSTD 10-99*, and the International One and Two Family Dwelling Code or Supplements thereto.

9. LIMITATIONS

- 9.1 This Evaluation Report and the installation instructions, when required by the building official, shall be submitted at the time of permit application.
- 9.2 Design loads on the Hurri-Bolt™ Anchors shall be determined in accordance with Chapter 16 of the *Standard Building Code©*.
- 9.3 Framing members (wood, masonry, concrete, steel, etc.) connected with the Hurri-Bolt™ Anchors shall be designed in accordance with the requirements of their appropriate design specifications as referenced in the *Code*.
- 9.4 Loads applied shall not exceed those recommended by the manufacturer as shown in Section 4.3.

- 9.5 When using SSTD 10-99, the design loads listed in the standard shall not exceed those recommended by the manufacturer as shown in Section 4.3.
- 9.6 Each package of Hurri-Bolt™ Anchors components shall contain the manufacturer's installation instructions.
- 9.7 Hurri-Bolt™ Anchors that are exposed directly to weather or subject to salt corrosion in coastal areas, as determined by the local building official, shall be galvanized in accordance with 302.1.3 of SSTD 10-99.
- 9.8 Hurri-Bolt™ Anchors shall not be installed in grouted masonry lintels or bond beams. Hurri-Bolt Anchors may be installed in formed concrete lintels or bond beams used as part of a masonry wall. The concrete lintels or bond beams shall have a minimum compressive strength of 2,500 psi. Design loads for the anchors shall be as noted in this report.
- 9.9 Special Inspection is required for installing Hurri-Bolt Epoxy Studs HBE with Hurri-Bolt Epoxy HB22, HB10 and Hurri-Wedge Anchors, see section 5.4 of this report.

10. IDENTIFICATION

Each package of Hurri-Bolt™ Anchors covered by this report shall be labeled with the manufacturer's name and/or trademark, the SBCCI Public Safety Testing and Evaluation Services Inc. Seal or initials (SBCCI PST & ESI), and the number of this report for field identification.

11. PERIOD OF ISSUANCE

SEE CURRENT SBCCI PST & ESI EVALUATION REPORT LISTING FOR STATUS OF THIS EVALUATION REPORT.

For information on this report contact:
 Michael P. O'Reardon, P.E.
 205/599-9800
moreardon@sbccies.org